

479503

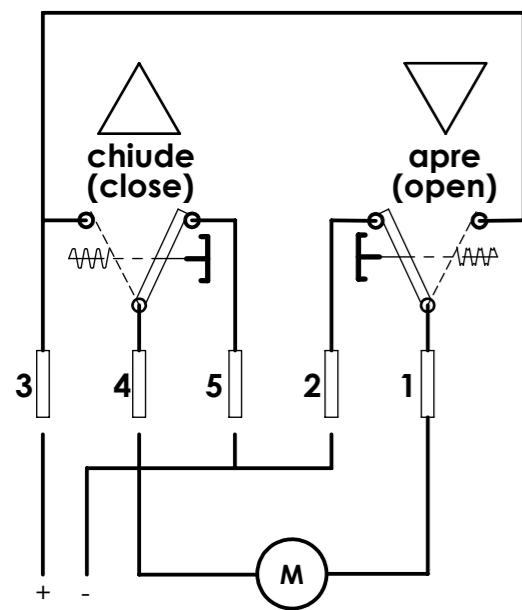

Motore

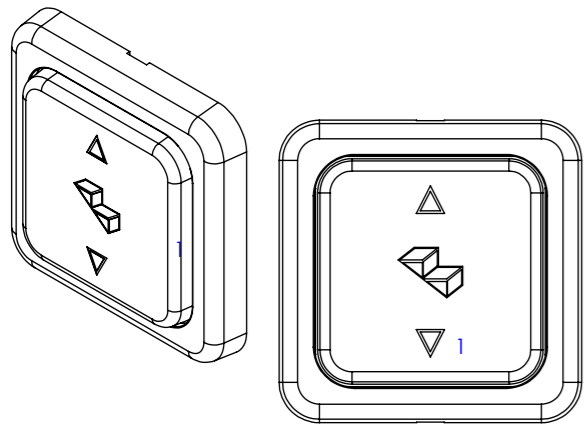
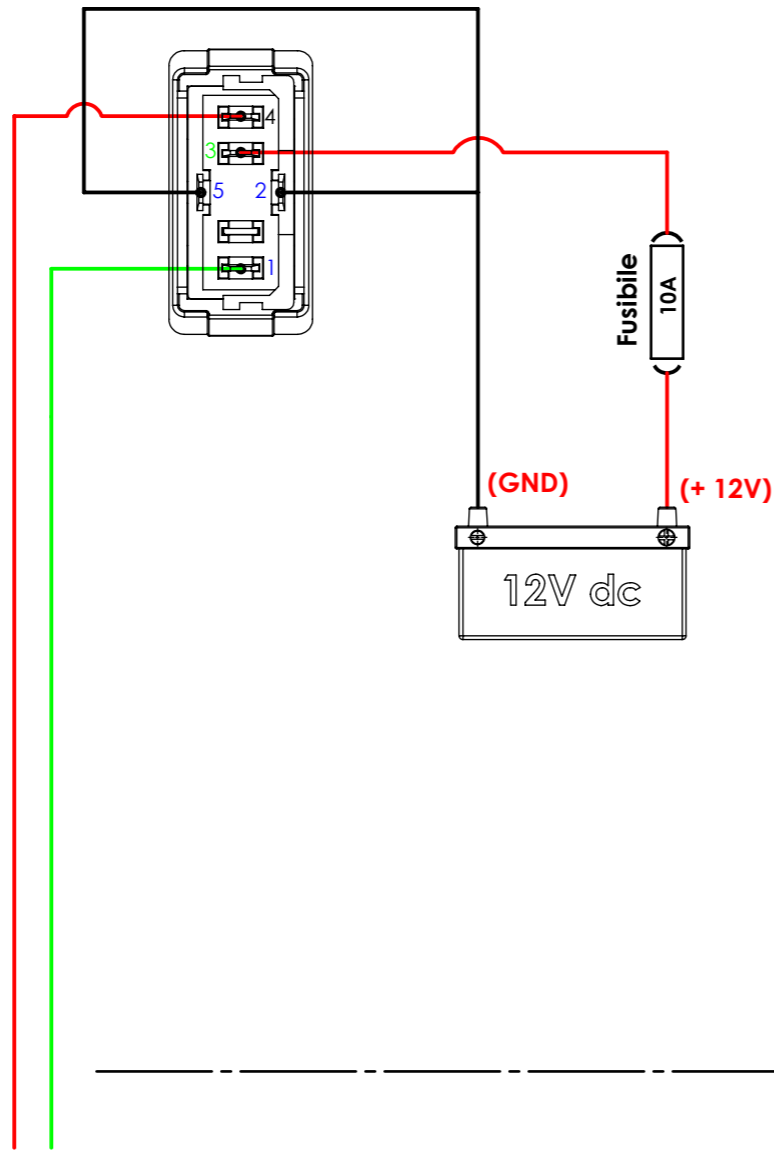

Schema di collegamento esterno al dispositivo (a cura del cliente)

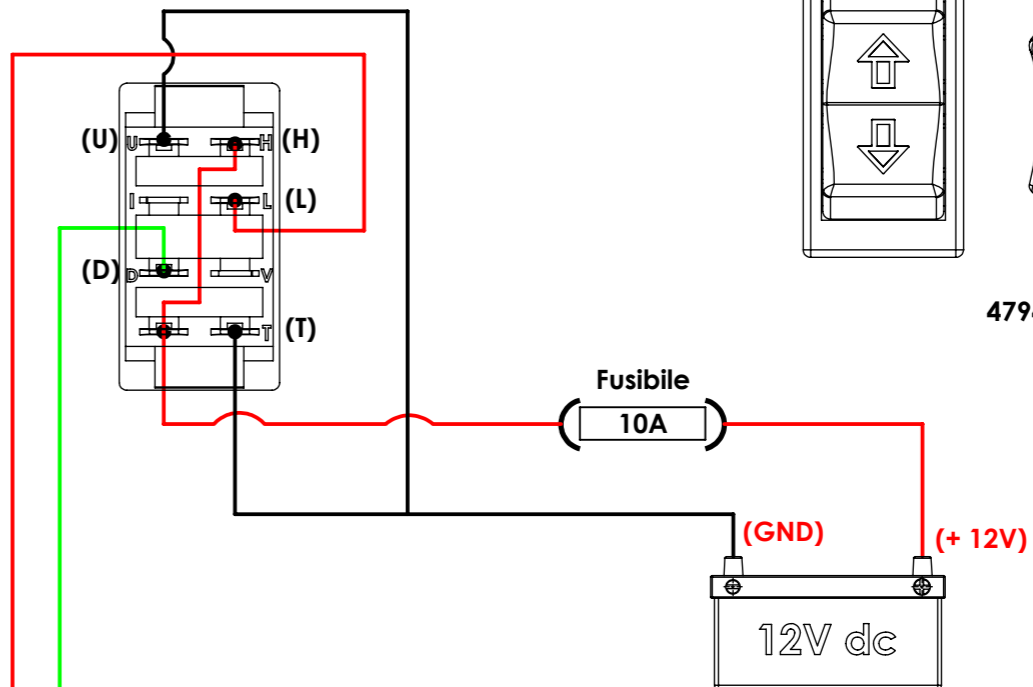

NOTA: - Lo schema è valido solo se si utilizza l'interruttore art. 080-10004

479497

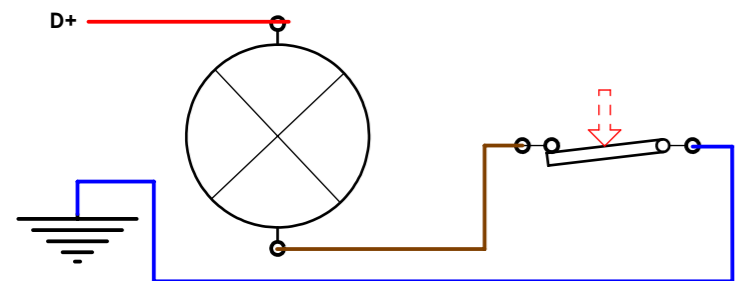
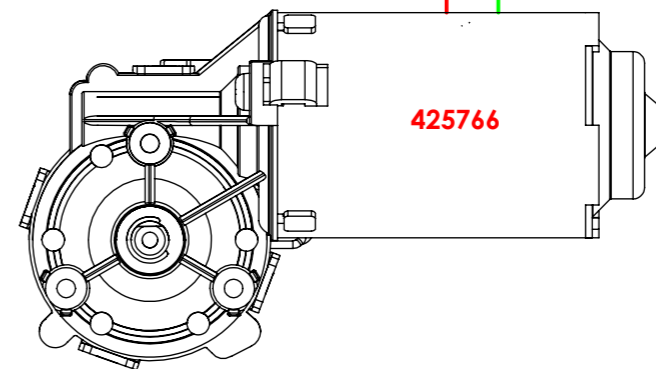
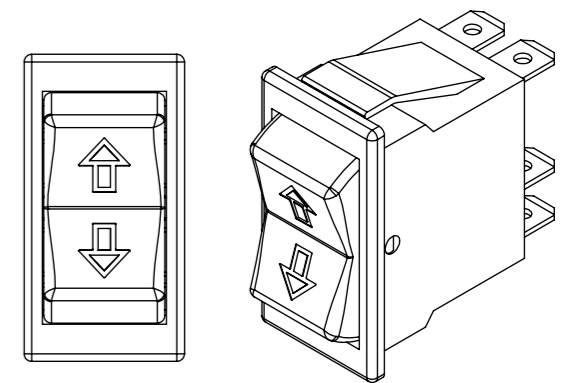

STEP OPEN: WARNING LIGHT ON WHEN TURN THE VEHICLE ON

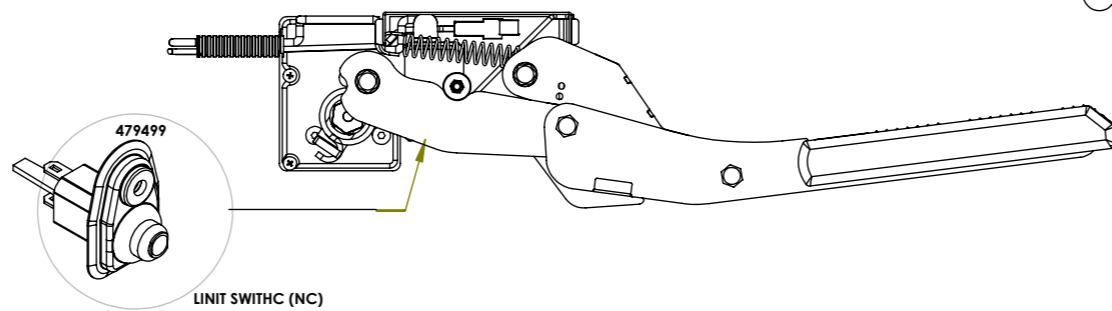

LIMIT SWITHC (NC)

Rev.	Data modifica	Controllato/Approvato	Descrizione modifica			
Ed. 1	Codice articolo		Descrizione			
	060-501003-IT		Schema di collegamento gradino			
Data ult.mod.	Data	Disegnato	Approvato	Vista	Scala	Foglio
01/03/2017	10/12/2010	A.V.	Nardini D.	--	--	01
14:49:21	RIF. Matricola >>	DAL N°	AL N°	Assorbimento	Peso (Kg)	Controllato
	>>>>	--	--	--	--	Nardini D.

Project 2000 S.r.l. si riserva tutti i diritti consentiti dalla legge sulla proprietà del seguente disegno. La divulgazione sia parziale che totale a terzi è assolutamente vietata.